



TR Electronic
Presents.....



PowerGap Signal & Power Transfer

Steve Cecchini

- Experience spanning two decades implementing sensor and feedback solutions in a multitude of different industries across North America .
- Currently the Regional Sales Manager of the Midwest.



Tristan Pawluch

-13+ years implementing, troubleshooting, piloting and retrofitting solutions for power generation and positioning feedback applications across North America.

-Currently the Applications and Training Supervisor for North America.



Agenda

- TR Electronic
- PowerGap Demo Video
- What is it?
- Terminology
- PowerGap Systems
- Applications
- Press Monitoring & Control
- Questions



TR Electronic



TR Electronic is a:

Designer – Developer – Manufacturer – Distributor
....Of Rotary, Linear, Laser Measurement and Presence
Detection Devices.

Providing Measurement and Automation Solutions for the
Manufacturing Industry for over 25 years!

TR Electronic is also proud to have a dedicated
Training and Technical Service Center for **all** Industrial
Positioning and Sensing Solutions.



Providing our Customers with **OUTSTANDING** Customer Service and Support

“Thank you for assisting today. My guys were impressed with your knowledge and ability to assist further than originally expected. The great level of service is what separates the great companies that will gain return business from the "Also-rans". “ - Line Manager, Plant Engineering - Electrical



TR Electronic – Your exclusive North American source for:

TR Electronic, **SENSEable**, **di-soric**, Microsonic, and PowerGap

Unmatched Technical Support and Customer Service 24 /7, 365 Days of the year!

Let us earn your business – Our Goal, is Your Success

Trossingen, Germany



Power Gap

Power Gap

Demo Video

What is PowerGap?

- Inductive Coupling
- Simultaneous Sensor and Control Signal Transmission with Power Transmission up to 2 A
- Wireless / No Physical Connection
- THROUGH BARRIERS!!!!



Inductive Coupling

- Power and Signal transmission are performed by the inductive coupling principle.

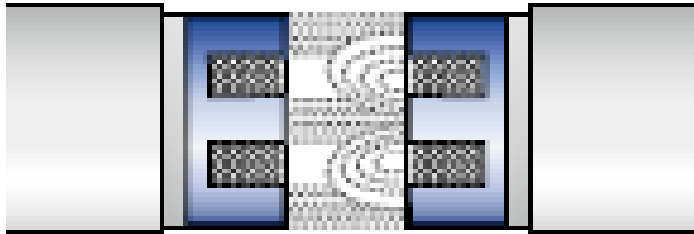

- Driving Current varies depending on the Operating Distance and Center Off-set.

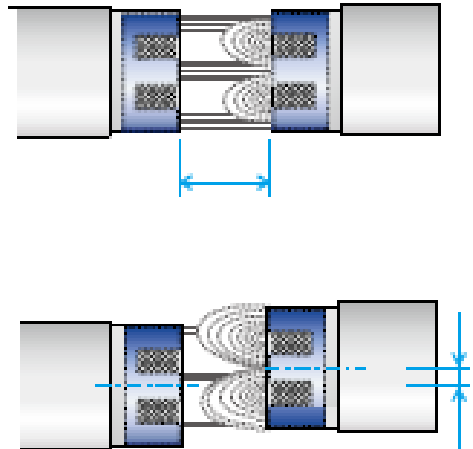

Power Gap Terminology

PowerGap Terminology

Remote:

This is the Moving Side of the system. Typically where sensors and actuators are mounted for sensing and control.

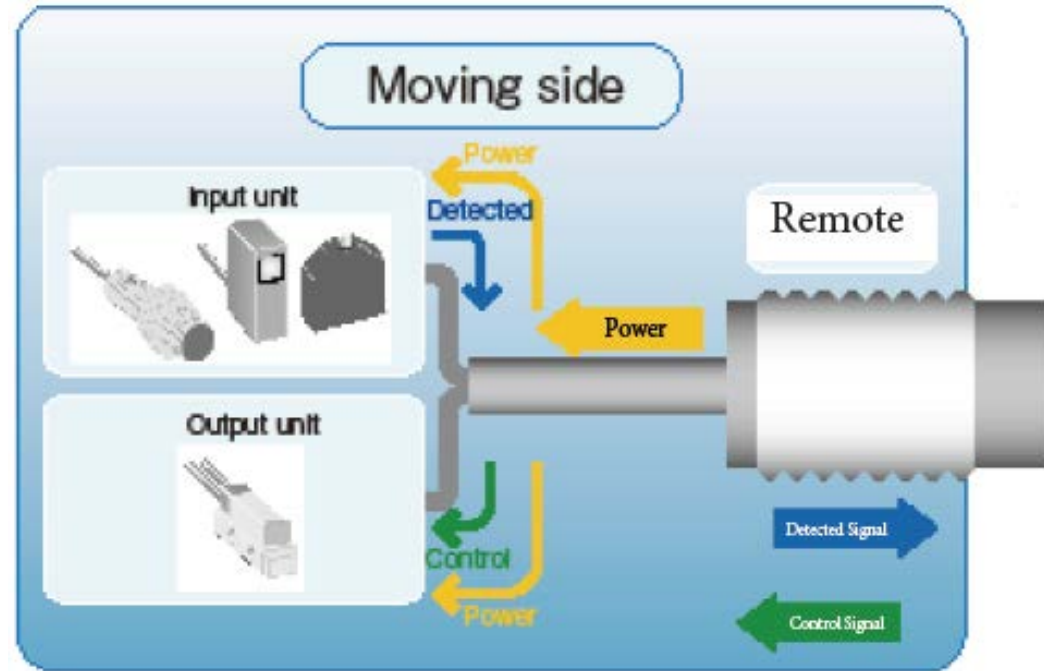

PowerGap Terminology

Base:

This is the Fixed Side of the system. Power Supply, PLC or other Control Systems would be mounted on this side.

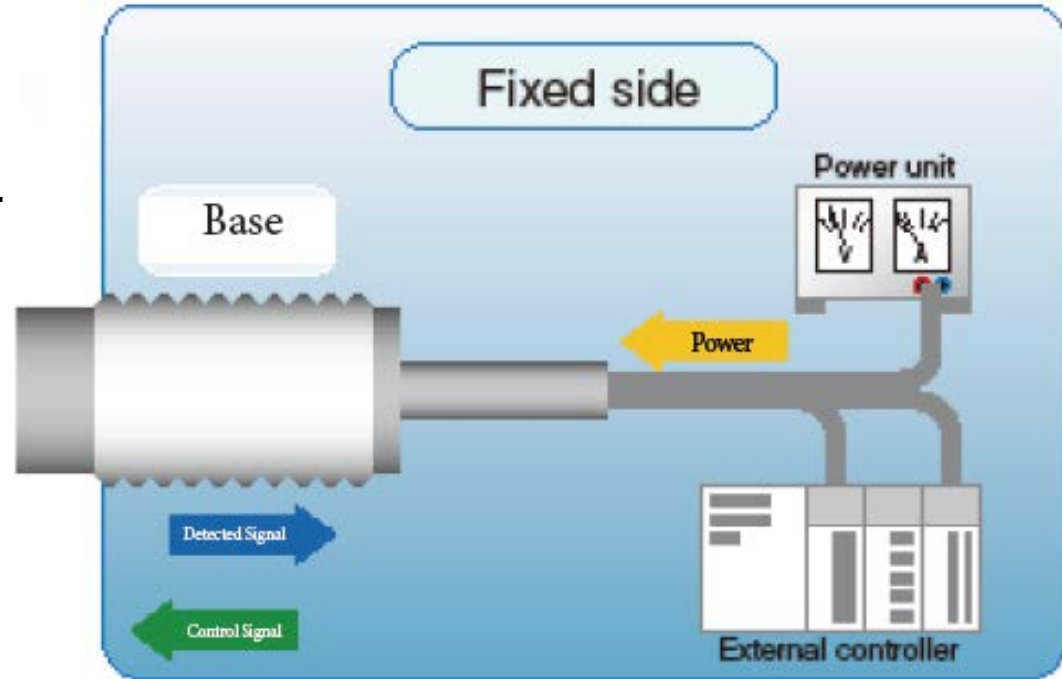

Product Features



- Power and Digital I/O Transmission
- EtherNet/IP, DeviceNet, CC Link Communication
- Transmission Through Partitions
- IP67 for Tough Environments
- Integrated In-Zone Signal

Power Gap Systems



PowerGap Systems



Power System

- Transmission of Power between Power Supply and Driving Unit

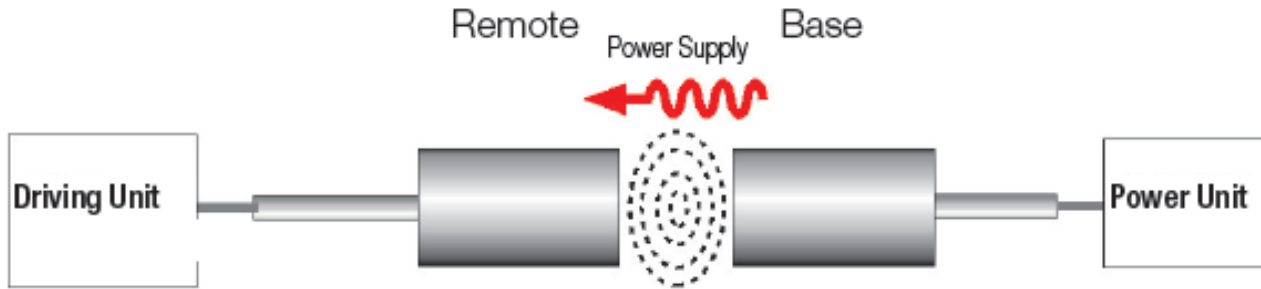



Sensor System

- The simultaneous supply of power to a sensor, switch, detector, etc... and the signal back to the controller.
- 1, 8 and 16 Inputs available

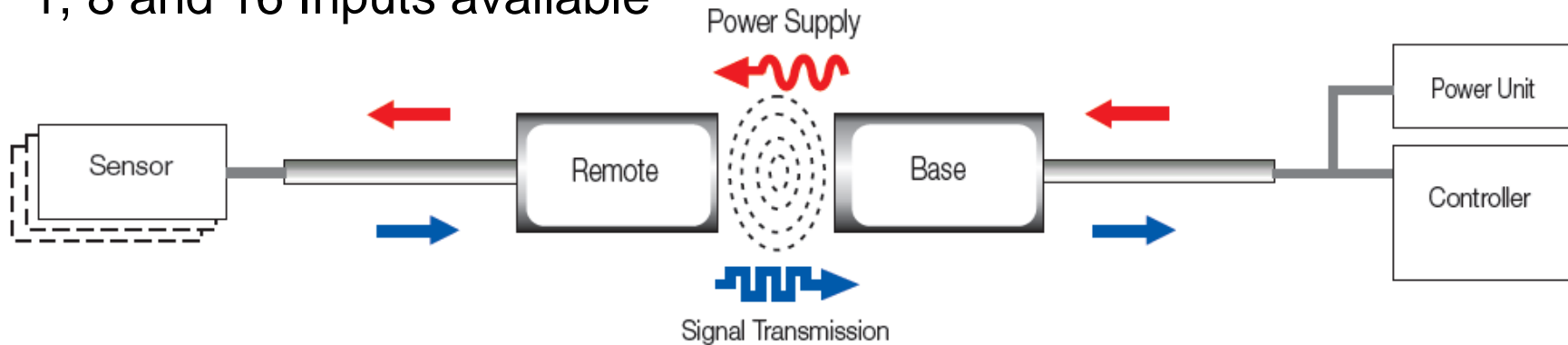



Coupler System

- The simultaneous supply of power to sensors and/or actuators... and the signals to and from the controller.
- Data communications of RS232 or DeviceNet

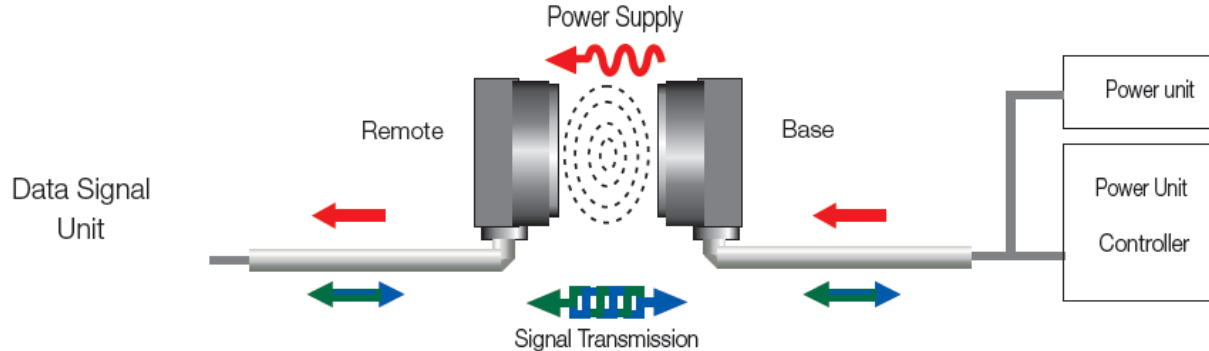



Link System

- The simultaneous supply of power to sensors and or actuators... and the signals to and from the controller with extended I/O abilities. DeviceNet, Ethernet/ IP, CC-Link

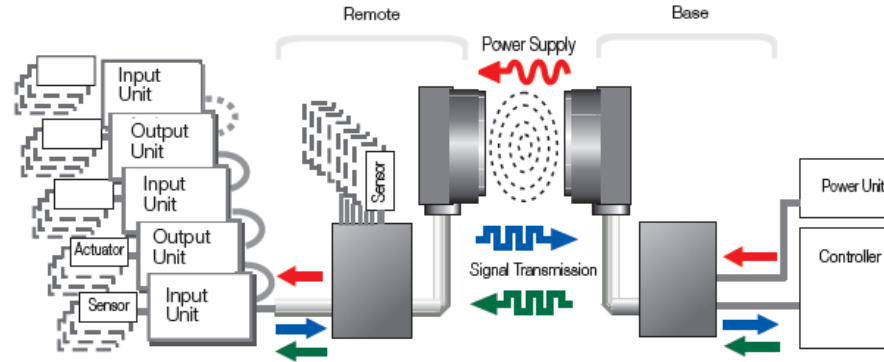

Applications

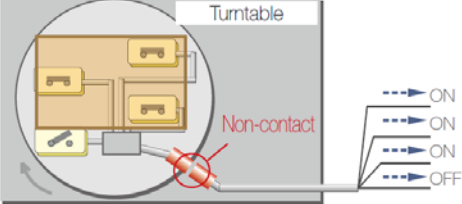
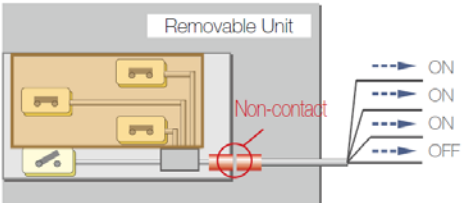
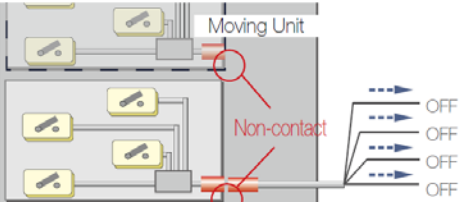

Advantages

<p>Rotary Unit</p> <p>⊙ No stress on cable Instant Changeout</p>		<ul style="list-style-type: none"> - No cable movement - No limitation of turning radius
<p>Interchangeable Unit</p> <p>⊙ Dust & Contamination OK</p>		<ul style="list-style-type: none"> - No connection labor - No wear and tear - No human error
<p>Moving Unit</p> <p>⊙ Requires only one transmitter</p>		<ul style="list-style-type: none"> - No cable movement - No physical connection - Protection class IP67

Applications

- Removable Jig Confirmation

Replacing Pallet Per Shape of Workpiece

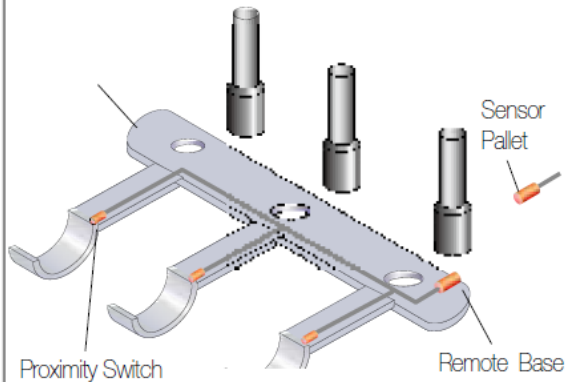

Placement of the Jig and Activation of Sensors at the Same Time

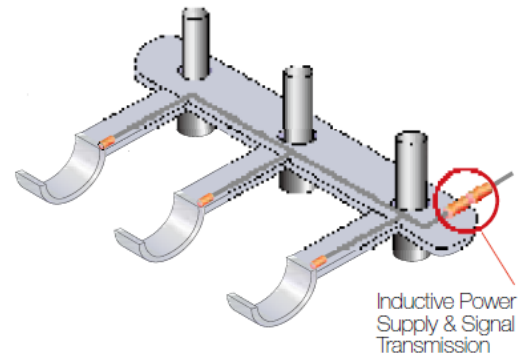

Confirming the Seating of Workpiece and Start Welding.

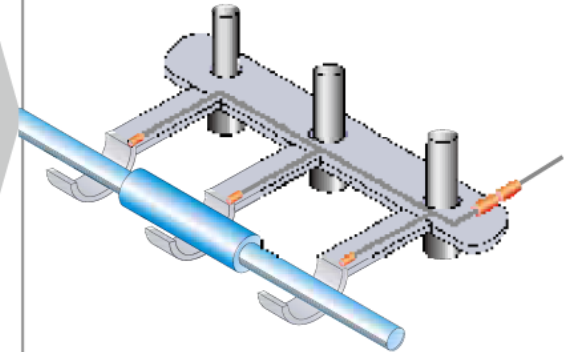

Applications

- Pallet Feedback

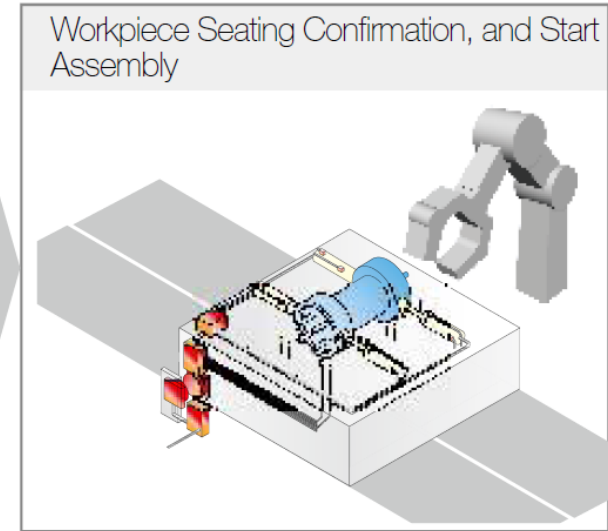
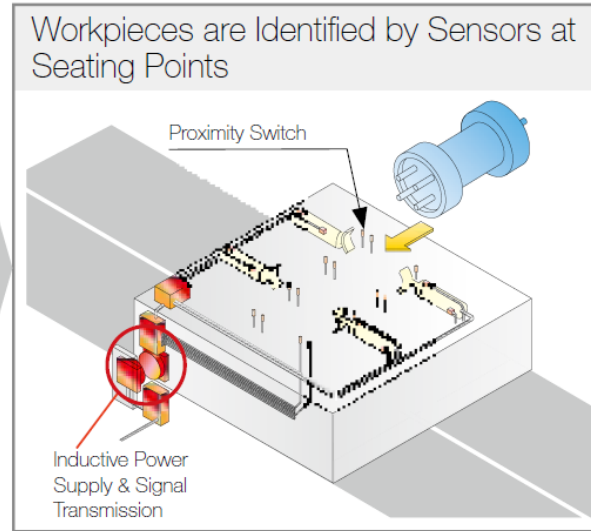
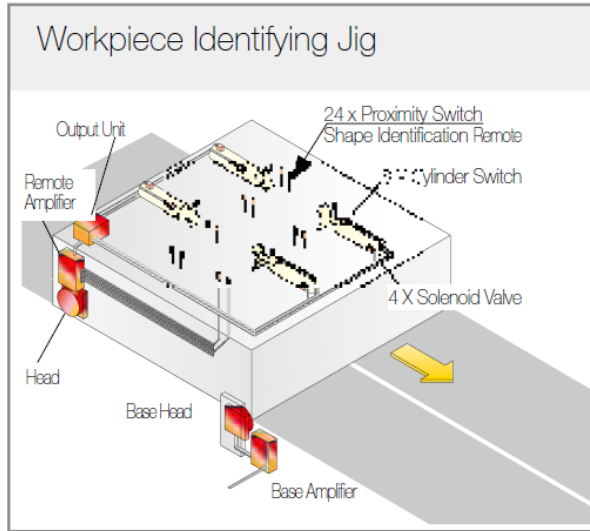

Applications

- Removable Jig's

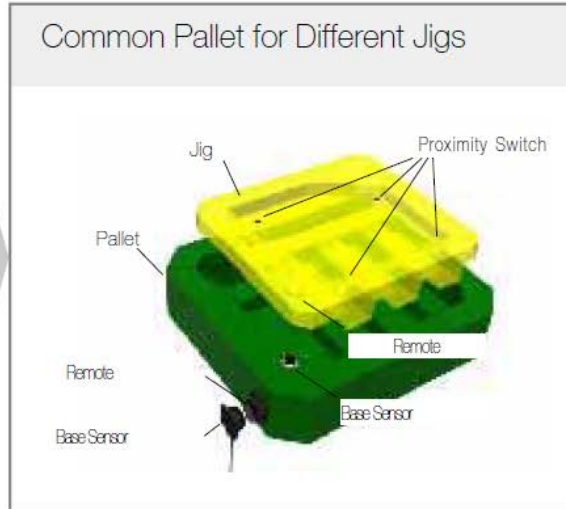
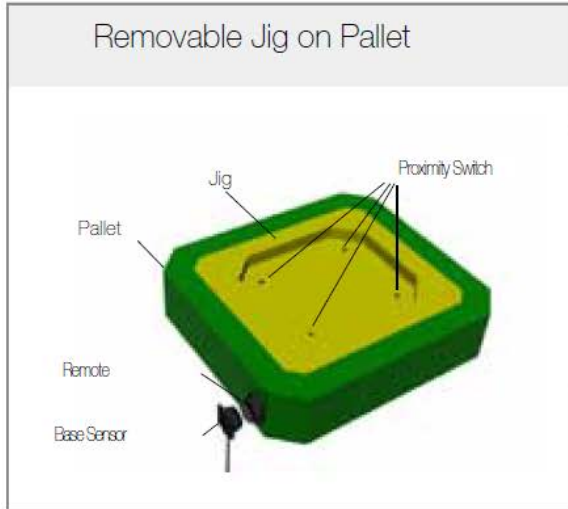

Applications

- Conveyor Shuttle

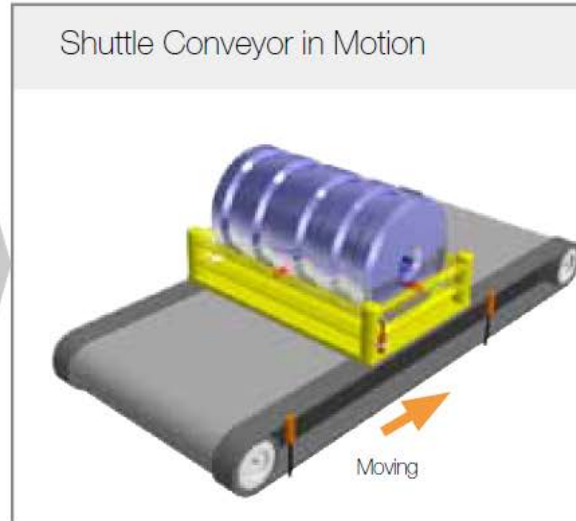
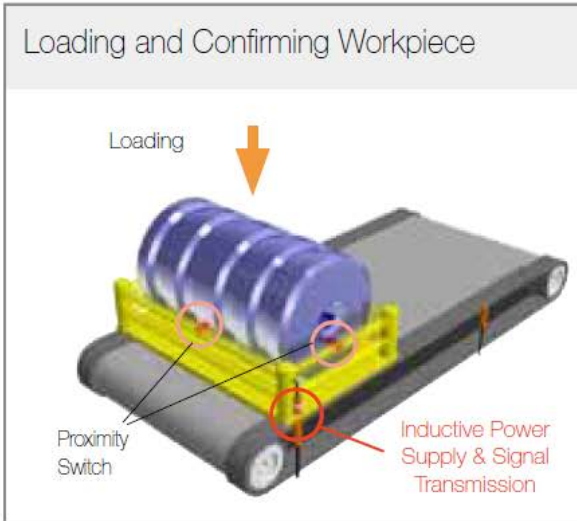

Applications

- AGV Charging

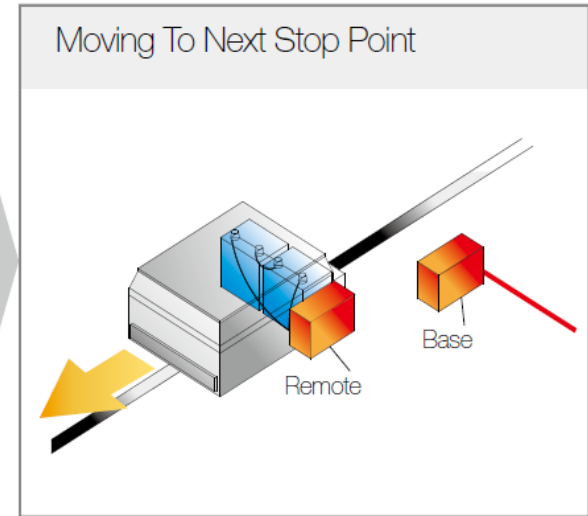
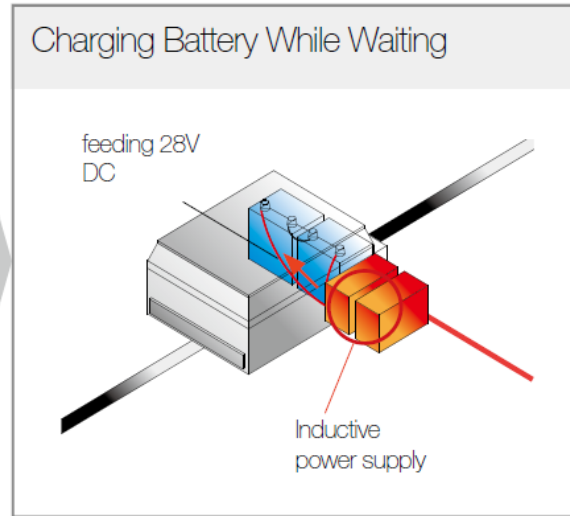
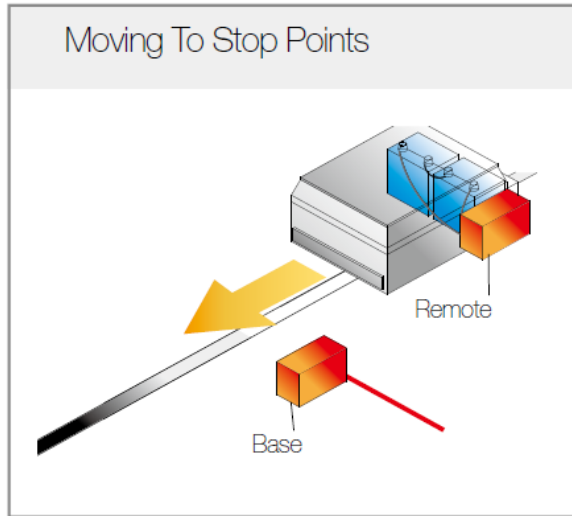

Applications

In Die Monitoring & Control

- Confirming workpiece within a die
- Powering in die monitoring /control systems.



Press Monitoring & Control





TRsystems has been a leader in the development of sensing solutions for the Stamping and Forming industry. We have pioneered much of what is today's state of the art technology. For over 30 yrs unidor has successfully installed thousands of systems around the world.



Understanding Stamping Tools

Knowing exactly what is happening inside your tool, is the basis for increased production, improved quality, minimal downtime and preventative maintenance.

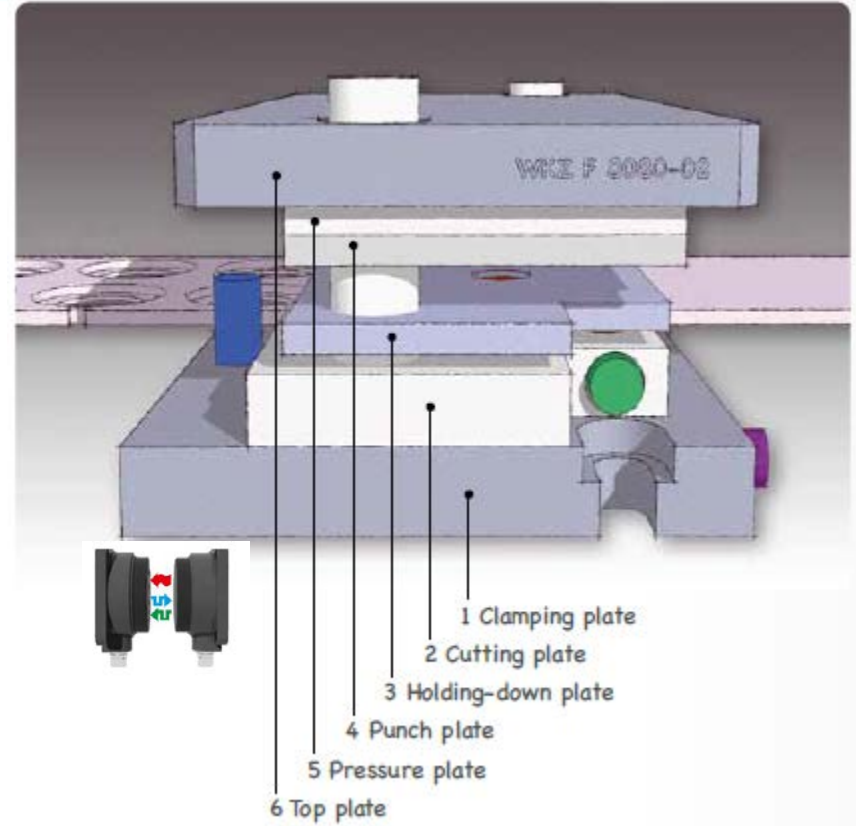

Sensors



TR ELECTRONIC
... *Passionate* about Sensors.

Encoders – these devices provide absolute press position. They give high position accuracy and resolution over the entire 360 degree stroke, to ensure the highest level of monitoring and control in the stamping process.



Optical – these sensors detect the presence/absence of an object or material. Frame sensors can be used at part ejection stations, feed monitoring and for positioning.

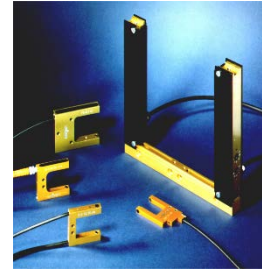

Inductive – these sensors detect the presence/absence of an object or material.



Acoustic – these sensors measure force curves. They are configured for either high or low frequency signals at the machine or in the tooling.

Eddy Current – these sensors monitor and measure the dimensional accuracy of parts. They are also ideal for monitoring double sheet detection.

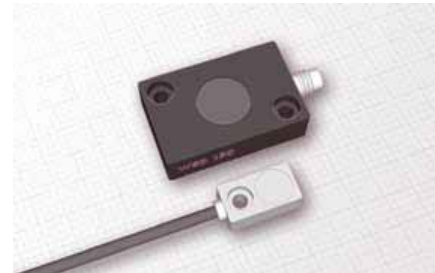

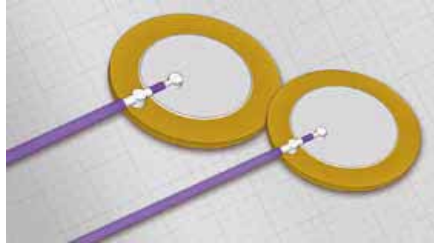

Piezo – these sensors measure force curves. The PSA sensors provide dynamic measuring of sound, pressure force and vibration. They can be used in the tool and at the machine.

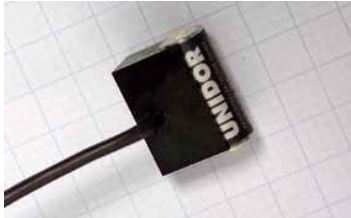



Eddy current sensors on the cutting plate measure and monitor the distance to the clamping plate. They are used used for double sheet and slug detection.

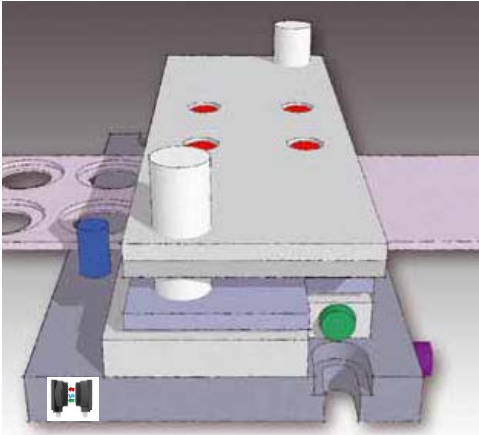

PSA sensors in the pressure plate show the force curve of the stamp. Any changes to a normal curve indicate wear or breakage.

PSA sensors in the tool hold-down plate provide a force-sound-signal curve for the forming process. Deviations in this curve highlight forming errors and quality issues.

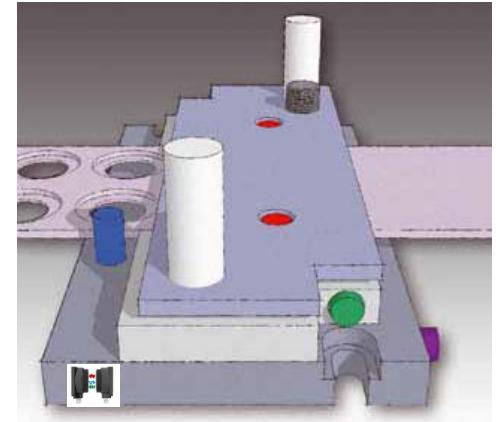

And more!

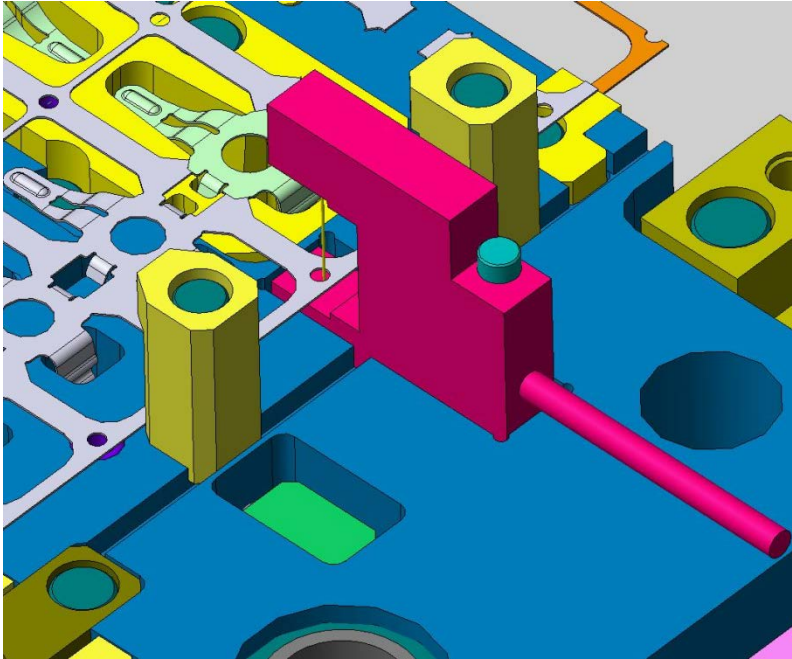

Optical sensors on the clamping plate can measure feed position as well as presence.

The Unidor System Product Line



The Unidor System Product Line

1. compactPRESS

- compactPRESS *smart* LINE 10.4" screen
- compactPRESS *eco* LINE 12" screen
- compactPRESS *star* LINE 15" screen

2. powerPRESS

-Takes complete control of the press operation and monitoring.
The all-in-one package!!!

smart CONTROL Architecture

compactPress protects your machines and dies. It provides a complete press monitoring system, which ensures regular maintenance and service, as well as archives all production and quality data.

As a stand-alone system or as a PLC sub-system of a main controller, compactPress can provide real time data for press operation.

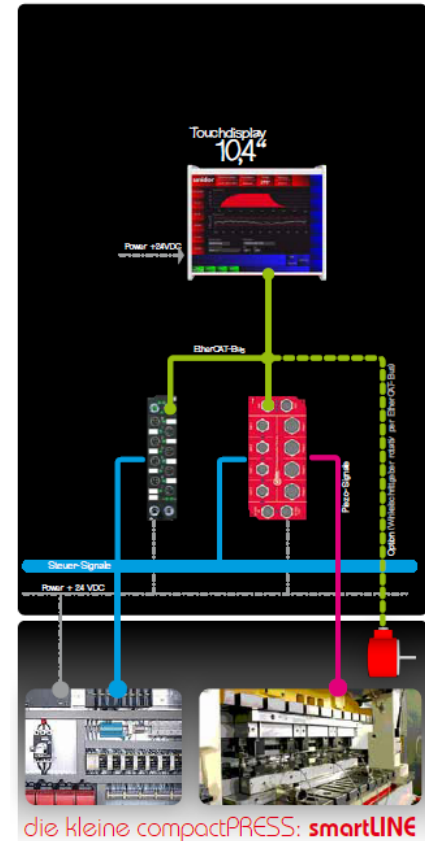

smartCONTROL Architecture

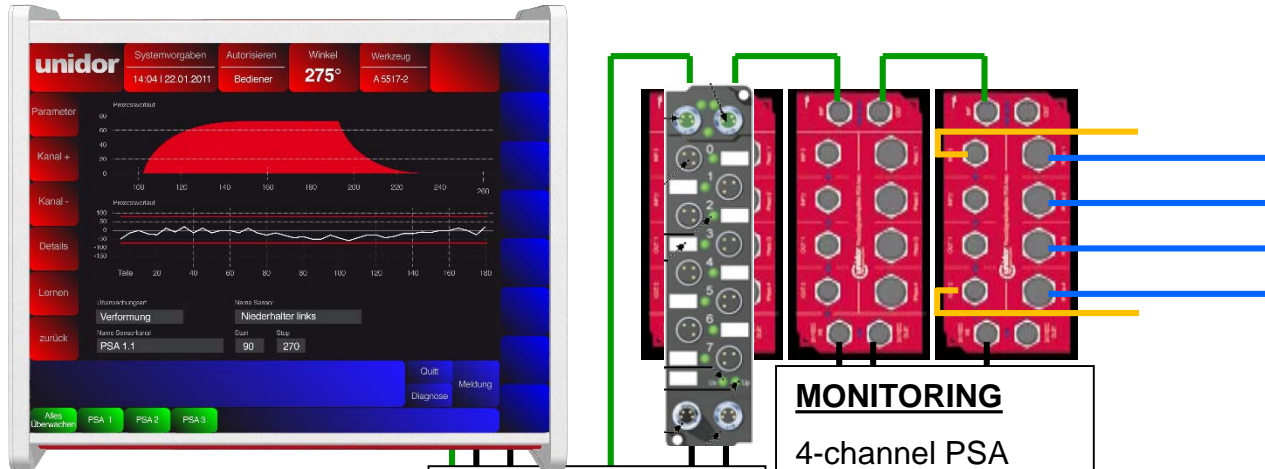

Possible variations

- 4-channel PSA monitoring
- 2-channel TON machine
- 2-channel TON In-Die
- 8-channel Die-Pro

-8 Digital Inputs
-6 or 8 Channel Die-Pro

MONITORING
4-channel PSA
4-channel TON
Machine
OR
4-channel TON
In-Die

Power supply 24V DC Ind Ethernet Bus PSA Sensor inputs (max. 12) Machine I/O interface

smartCONTROL Architecture

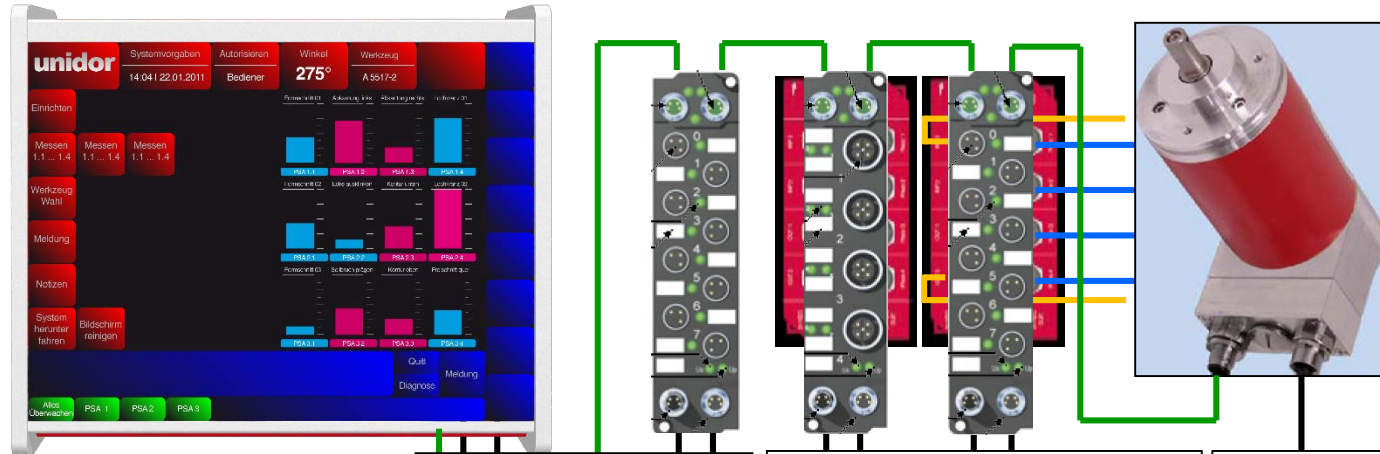

- Possible variations 3.**
- 4 4-channel Slug-Detection
 - 2 8-Part Counters
 - 2 6-channel Die-Pro
 - 8 5-Programmable Cams

-8 Digital Inputs
-6 or 8 Channel Die-Pro

-4 Analogue Inputs
-4 Channel Slug-Detection

Encoder 360°
Real-Time Monitoring

-8 Digital Outputs
-6 or 8 Cams

Power supply 24V DC

Ind Ethernet Bus

PSA Sensor inputs (max. 12)

Machine I/O interface

smartCONTROL Architecture

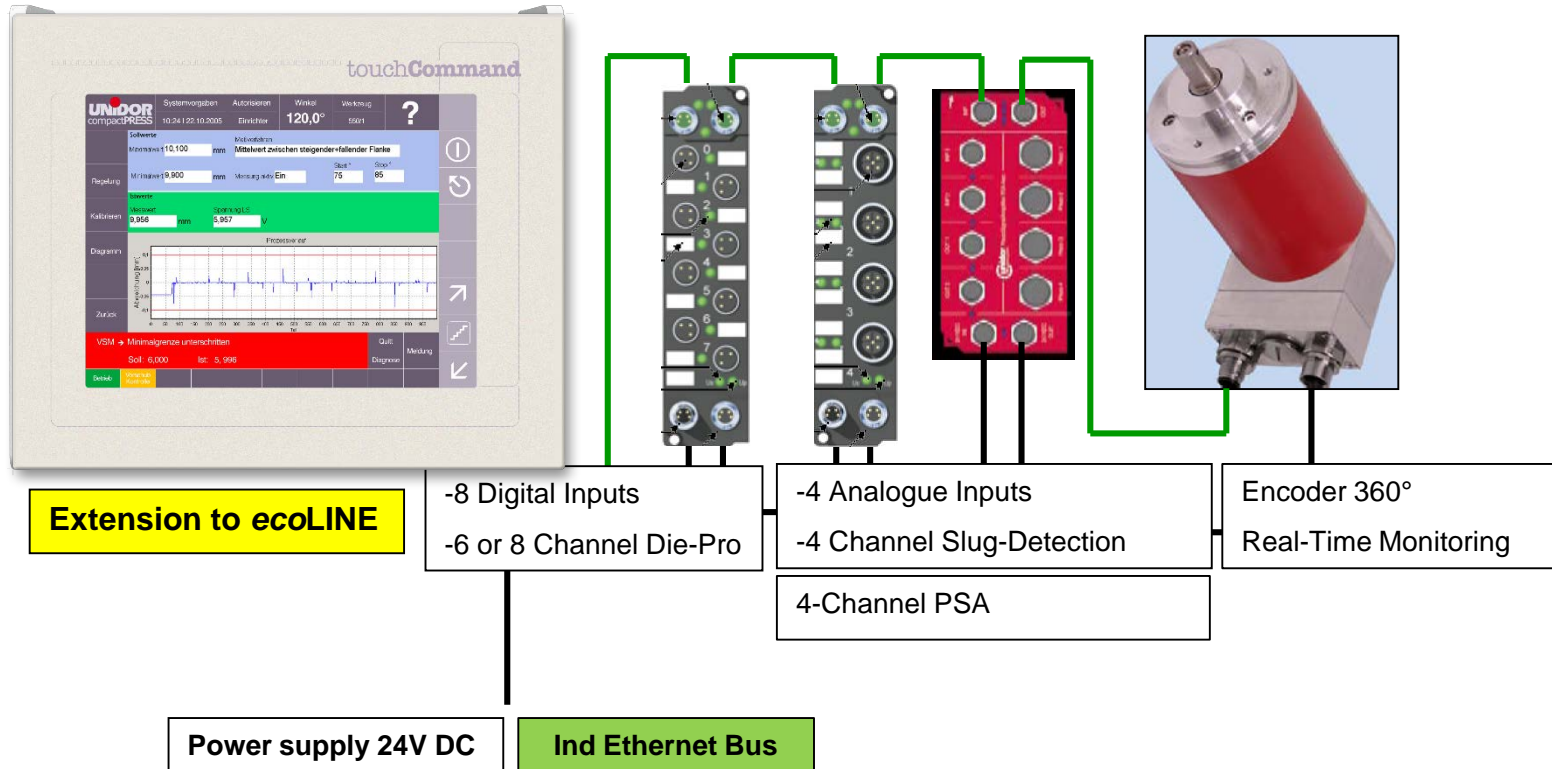

smartCONTROL Architecture

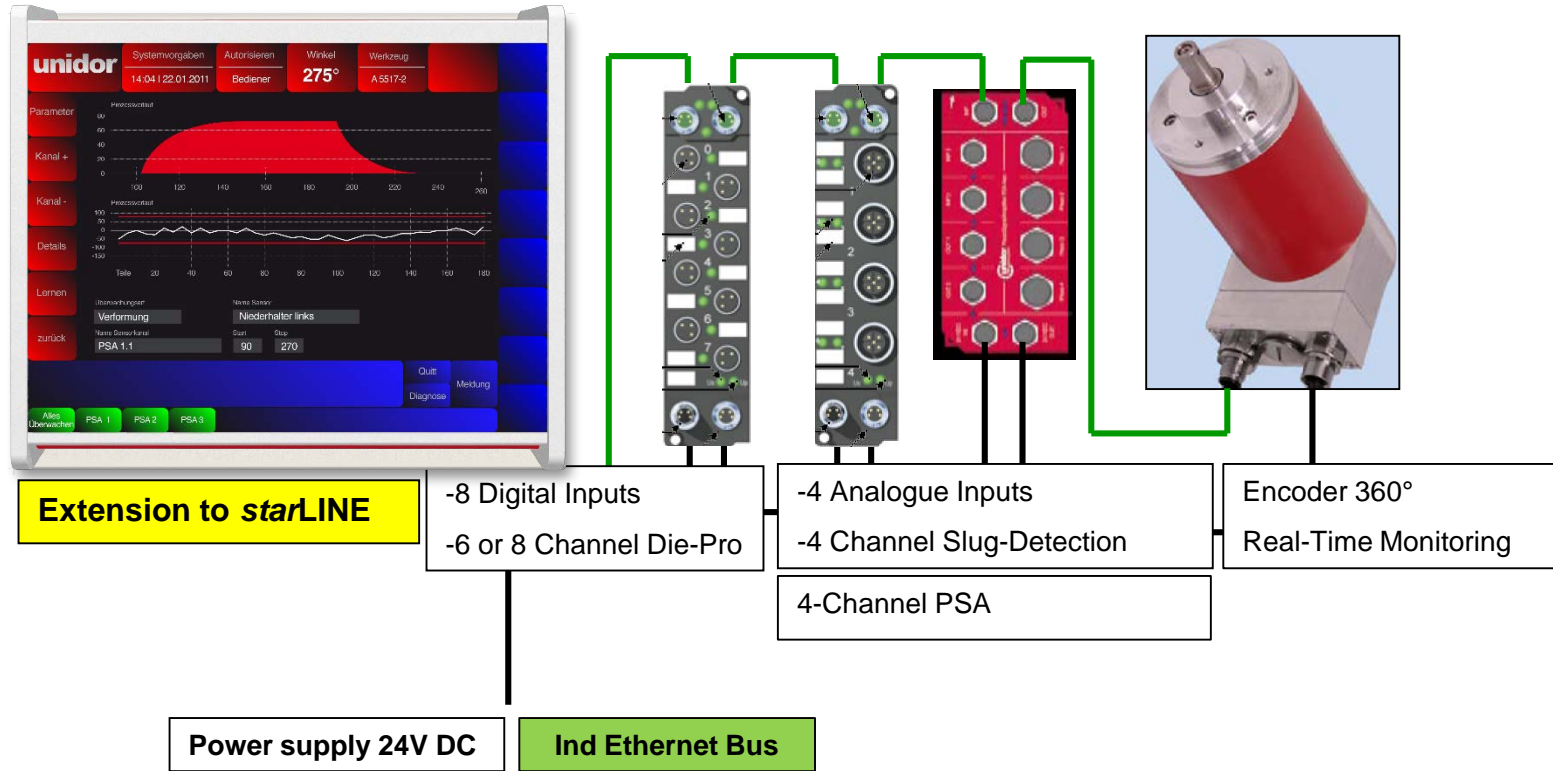

Extension to starLINE

-8 Digital Inputs
-6 or 8 Channel Die-Pro

-4 Analogue Inputs
-4 Channel Slug-Detection

4-Channel PSA

Encoder 360°
Real-Time Monitoring

Power supply 24V DC

Ind Ethernet Bus

smartCONTROL Architecture

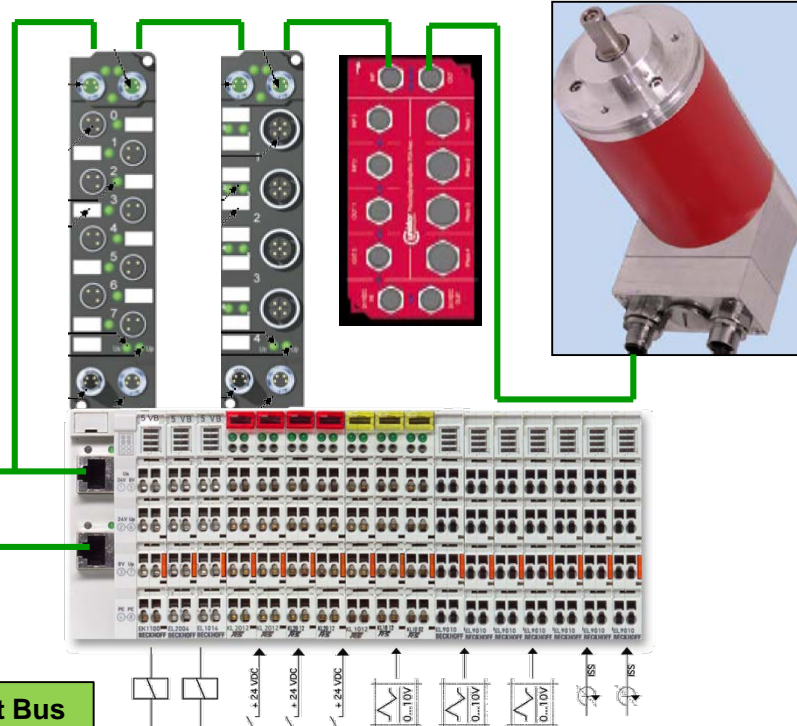
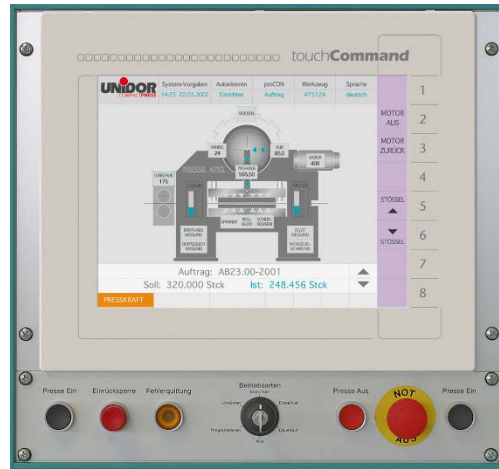

Extension with Beckhoff – Terminals

Ind Ethernet Bus

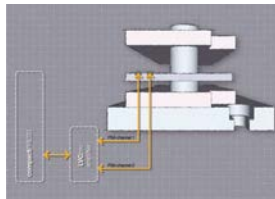
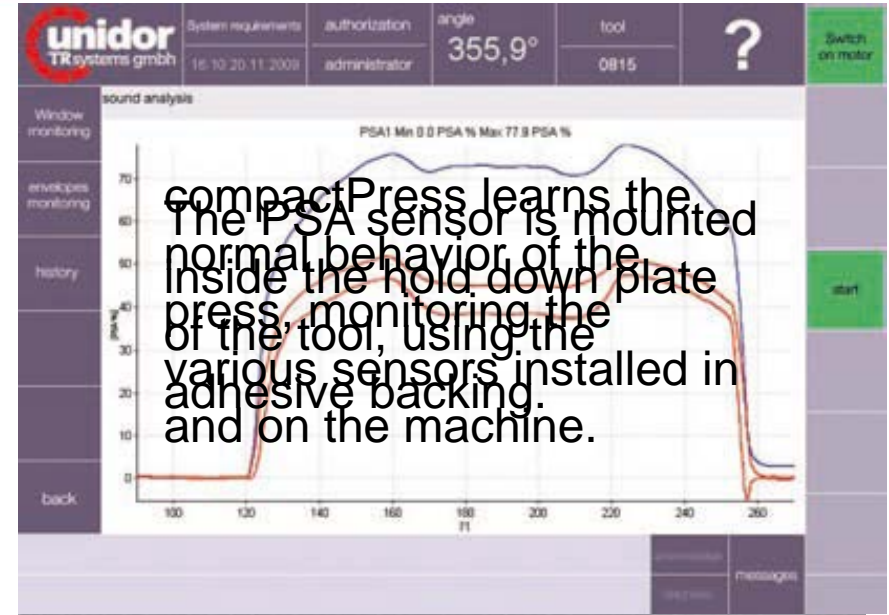
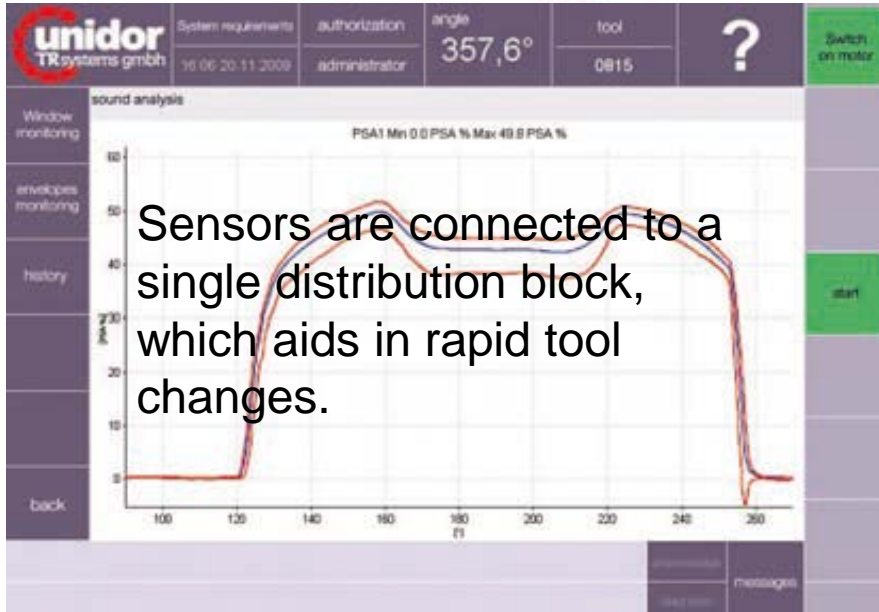

Benefits

Not To Press-ure You,
But There Are TONS!



Benefits Of Press Monitoring

- ✓ Increase in Quality
- ✓ Lower Unplanned Downtime
- ✓ Increase in Production Monitoring
- ✓ Increase in Process Awareness
- ✓ Improved Maintenance Tracking
- ✓ Increase in Equipment Utilization



QUESTIONS?





Putting Our Customers First!

www.trelectronic.com

customercare@trelectronic.com



Proud Member of:



**ISO
9001**
QUALITY
ASSURANCE



www.trelectronic.com | 1 800 265 9483